

# Econ 204 2023

## Lecture 3

### Outline

1. Metric Spaces and Normed Spaces
2. Convergence of Sequences in Metric Spaces
3. Sequences in  $\mathbf{R}$  and  $\mathbf{R}^n$

# Metric Spaces and Metrics

Generalize distance and length notions in  $\mathbf{R}^n$

**Definition 1.** A metric space is a pair  $(X, d)$ , where  $X$  is a set and  $d : X \times X \rightarrow \mathbf{R}_+$  a function satisfying

1.  $d(x, y) \geq 0$ ,  $d(x, y) = 0 \Leftrightarrow x = y \quad \forall x, y \in X$

2.  $d(x, y) = d(y, x) \quad \forall x, y \in X$

3. triangle inequality:

$$d(x, z) \leq d(x, y) + d(y, z) \quad \forall x, y, z \in X$$

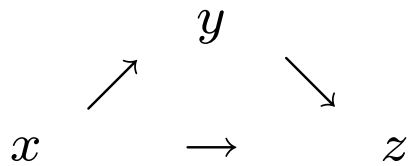

*A function  $d : X \times X \rightarrow \mathbf{R}_+$  satisfying 1-3 above is called a metric on  $X$ .*

A metric gives a notion of distance between elements of  $X$ .

# Normed Spaces and Norms

**Definition 2.** Let  $V$  be a vector space over  $\mathbf{R}$ . A norm on  $V$  is a function  $\| \cdot \| : V \rightarrow \mathbf{R}_+$  satisfying

1.  $\|x\| \geq 0 \quad \forall x \in V$

2.  $\|x\| = 0 \Leftrightarrow x = 0 \quad \forall x \in V$

3. triangle inequality:

$$\|x + y\| \leq \|x\| + \|y\| \quad \forall x, y \in V$$

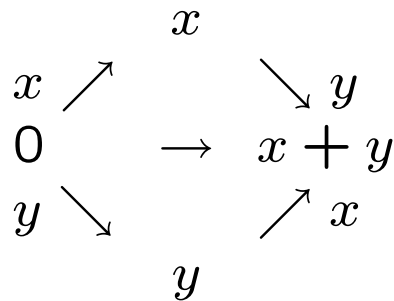

$$4. \|\alpha x\| = |\alpha| \|x\| \quad \forall \alpha \in \mathbf{R}, x \in V$$

A normed vector space is a vector space over  $\mathbf{R}$  equipped with a norm.

A norm gives a notion of length of a vector in  $V$ .

# Normed Spaces and Norms

**Example:** In  $\mathbf{R}^n$ , standard notion of distance between two vectors  $x$  and  $y$  measures length of difference  $x - y$ , i.e.,  
$$d(x, y) = \|x - y\| = \sqrt{\sum_{i=1}^n (x_i - y_i)^2}.$$

In an abstract normed vector space, the norm can be used analogously to define a notion of distance.

**Theorem 1.** *Let  $(V, \|\cdot\|)$  be a normed vector space. Let  $d : V \times V \Rightarrow \mathbf{R}_+$  be defined by*

$$d(v, w) = \|v - w\|$$

*Then  $(V, d)$  is a metric space.*

*Proof.* We must verify that  $d$  satisfies all the properties of a metric.

1. Let  $v, w \in V$ . Then by definition,  $d(v, w) = \|v - w\| \geq 0$  (why?), and

$$\begin{aligned}d(v, w) = 0 &\Leftrightarrow \|v - w\| = 0 \\&\Leftrightarrow v - w = 0 \\&\Leftrightarrow (v + (-w)) + w = w \\&\Leftrightarrow v + ((-w) + w) = w \\&\Leftrightarrow v + 0 = w \\&\Leftrightarrow v = w\end{aligned}$$

2. First, note that for any  $x \in V$ ,  $0 \cdot x = (0 + 0) \cdot x = 0 \cdot x + 0 \cdot x$ , so  $0 \cdot x = 0$ . Then  $0 = 0 \cdot x = (1 - 1) \cdot x = 1 \cdot x + (-1) \cdot x =$

$x + (-1) \cdot x$ , so we have  $(-1) \cdot x = (-x)$ . Then let  $v, w \in V$ .

$$\begin{aligned}d(v, w) &= \|v - w\| \\&= |-1| \|v - w\| \\&= \|(-1)(v + (-w))\| \\&= \|(-1)v + (-1)(-w)\| \\&= \|-v + w\| \\&= \|w + (-v)\| \\&= \|w - v\| \\&= d(w, v)\end{aligned}$$



3. Let  $u, w, v \in V$ .

$$\begin{aligned}d(u, w) &= \|u - w\| \\&= \|u + (-v + v) - w\| \\&= \|u - v + v - w\| \\&\leq \|u - v\| + \|v - w\| \\&= d(u, v) + d(v, w)\end{aligned}$$

Thus  $d$  is a metric on  $V$ .



# Normed Spaces and Norms

## Examples

- $\mathbf{E}^n$ :  $n$ -dimensional Euclidean space.

$$V = \mathbf{R}^n, \|x\|_2 = |x| = \sqrt{\sum_{i=1}^n (x_i)^2}$$

- $V = \mathbf{R}^n, \|x\|_1 = \sum_{i=1}^n |x_i|$  (the “taxi cab” norm or  $L^1$  norm)
- $V = \mathbf{R}^n, \|x\|_\infty = \max\{|x_1|, \dots, |x_n|\}$  (the maximum norm, or sup norm, or  $L^\infty$  norm)

- $C([0, 1]), \|f\|_\infty = \sup\{|f(t)| : t \in [0, 1]\}$

- $C([0, 1]), \|f\|_2 = \sqrt{\int_0^1 (f(t))^2 dt}$

- $C([0, 1]), \|f\|_1 = \int_0^1 |f(t)| dt$

# Normed Spaces and Norms

**Theorem 2** (Cauchy-Schwarz Inequality).

*If  $v, w \in \mathbf{R}^n$ , then*

$$\begin{aligned}\left(\sum_{i=1}^n v_i w_i\right)^2 &\leq \left(\sum_{i=1}^n v_i^2\right) \left(\sum_{i=1}^n w_i^2\right) \\ |v \cdot w|^2 &\leq |v|^2 |w|^2 \\ |v \cdot w| &\leq |v| |w|\end{aligned}$$

## Equivalent Norms

A given vector space may have many different norms: if  $\|\cdot\|$  is a norm on a vector space  $V$ , so are  $2\|\cdot\|$  and  $3\|\cdot\|$  and  $k\|\cdot\|$  for any  $k > 0$ .

Less trivially,  $\mathbf{R}^n$  supports many different norms as in the examples above. Different norms on a given vector space yield different geometric properties.

standard norm

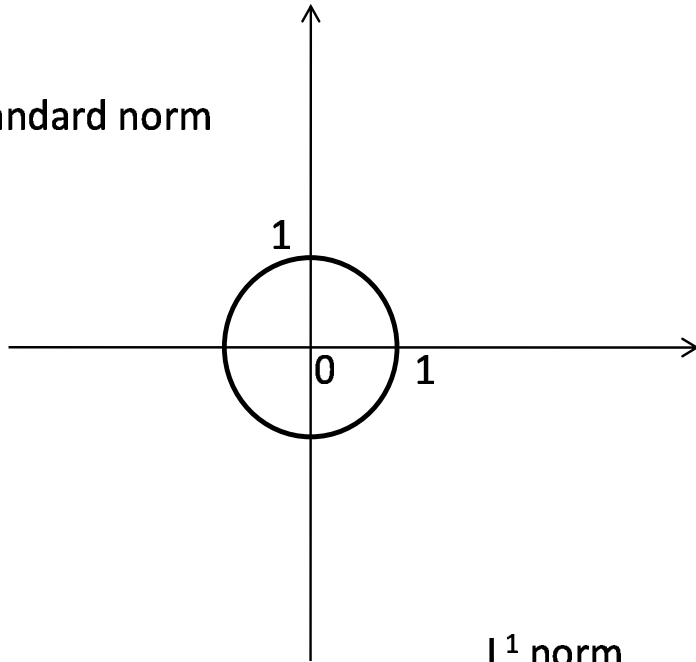

sup norm

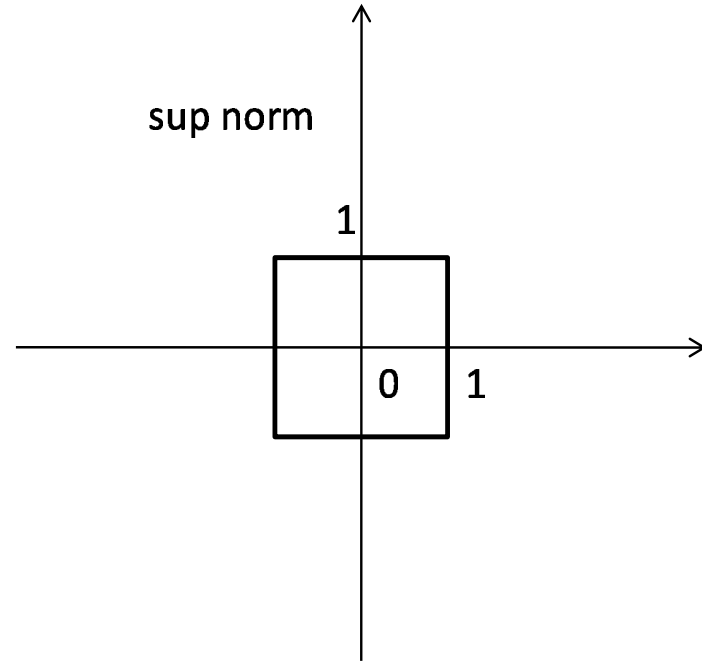

$L^1$  norm

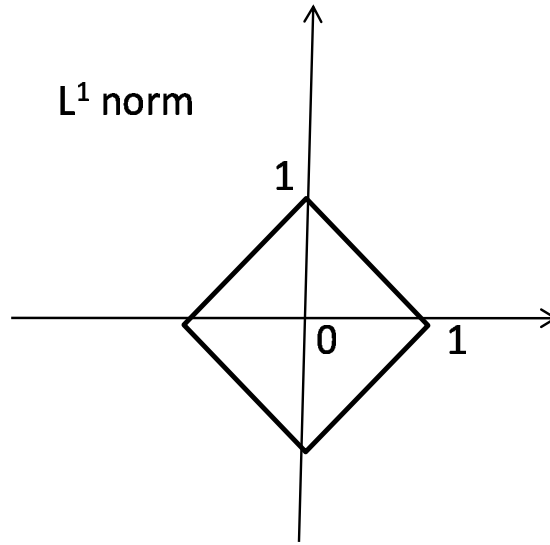

unit balls around 0 in different norms

## Equivalent Norms

**Definition 3.** Two norms  $\| \cdot \|$  and  $\| \cdot \|^{*}$  on the same vector space  $V$  are said to be Lipschitz-equivalent ( or equivalent ) if  $\exists m, M > 0$  s.t.  $\forall x \in V$ ,

$$m\|x\| \leq \|x\|^{*} \leq M\|x\|$$

Equivalently,  $\exists m, M > 0$  s.t.  $\forall x \in V, x \neq 0$ ,

$$m \leq \frac{\|x\|^{*}}{\|x\|} \leq M$$

# Equivalent Norms

If two norms are equivalent, then they define the same notions of convergence and continuity. For topological purposes, equivalent norms are indistinguishable.

For example, suppose two norms  $\|\cdot\|$  and  $\|\cdot\|^*$  on the vector space  $V$  are equivalent, and fix  $x \in V$ . Let

$$\begin{aligned} B_\varepsilon(x, \|\cdot\|) &= \{y \in V : \|x - y\| < \varepsilon\} \\ B_\varepsilon(x, \|\cdot\|^*) &= \{y \in V : \|x - y\|^* < \varepsilon\} \end{aligned}$$

Then for any  $\varepsilon > 0$ ,

$$B_{\frac{\varepsilon}{M}}(x, \|\cdot\|) \subseteq B_\varepsilon(x, \|\cdot\|^*) \subseteq B_{\frac{\varepsilon}{m}}(x, \|\cdot\|)$$



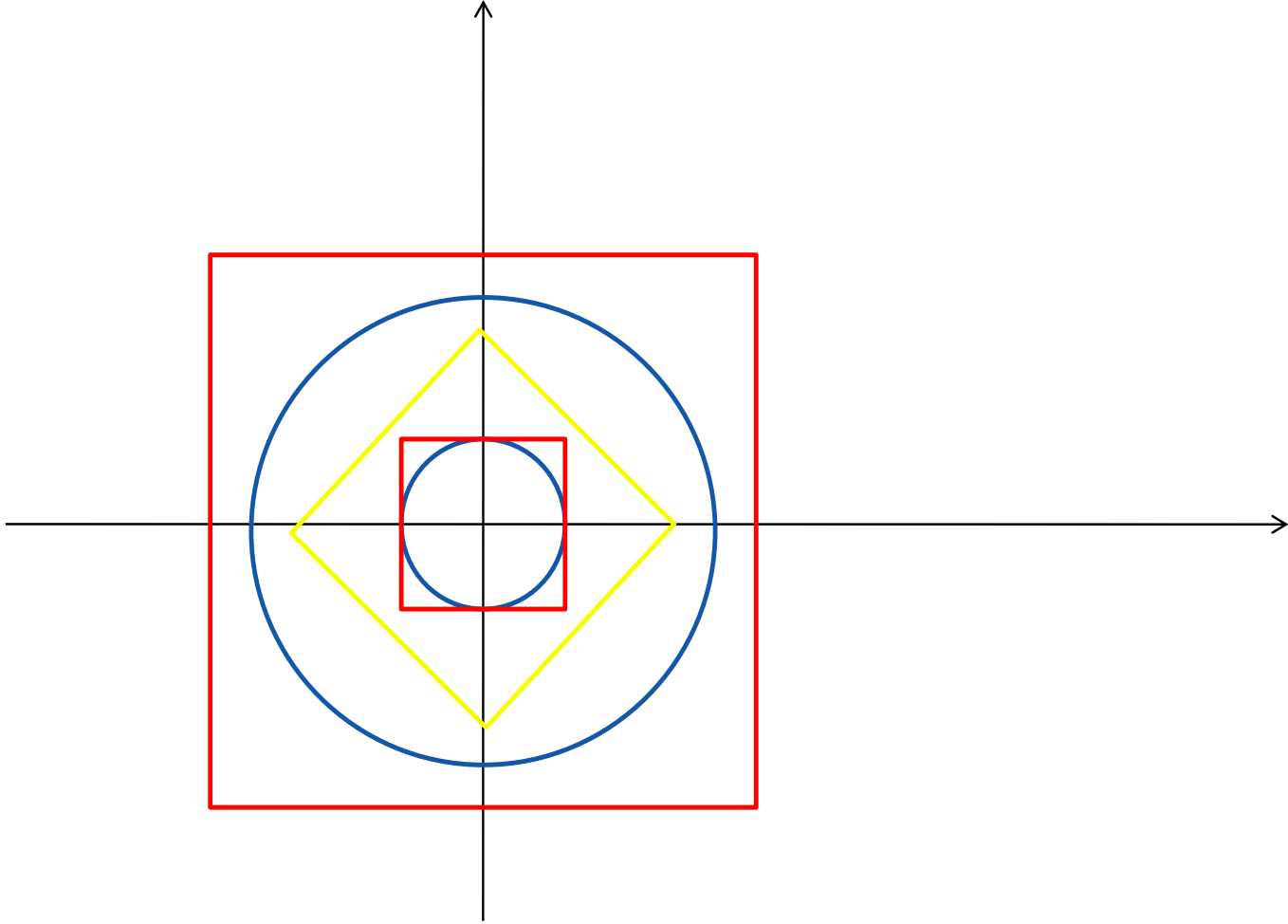

norms on  $\mathbf{R}^n$  are equivalent

## Equivalent Norms

In  $\mathbf{R}^n$  (or any finite-dimensional normed vector space), all norms are equivalent. Roughly, up to a difference in scaling, for topological purposes there is a unique norm in  $\mathbf{R}^n$ .

**Theorem 3.** *All norms on  $\mathbf{R}^n$  are equivalent.*

Infinite-dimensional spaces support norms that are not equivalent. For example, on  $C([0, 1])$ , let  $f_n$  be the function

$$f_n(t) = \begin{cases} 1 - nt & \text{if } t \in \left[0, \frac{1}{n}\right] \\ 0 & \text{if } t \in \left(\frac{1}{n}, 1\right] \end{cases}$$

Then

$$\frac{\|f_n\|_1}{\|f_n\|_\infty} = \frac{\frac{1}{2n}}{1} = \frac{1}{2n} \rightarrow 0$$

## Metrics and Sets

**Definition 4.** *In a metric space  $(X, d)$ , a subset  $S \subseteq X$  is bounded if  $\exists x \in X, \beta \in \mathbf{R}$  such that  $\forall s \in S, d(s, x) \leq \beta$ .*

In a metric space  $(X, d)$ , define

$$\begin{aligned} B_\varepsilon(x) &= \{y \in X : d(y, x) < \varepsilon\} \\ &= \text{open ball with center } x \text{ and radius } \varepsilon \end{aligned}$$

$$\begin{aligned} B_\varepsilon[x] &= \{y \in X : d(y, x) \leq \varepsilon\} \\ &= \text{closed ball with center } x \text{ and radius } \varepsilon \end{aligned}$$

# Metrics and Sets

We can use the metric  $d$  to define a generalization of “radius”. In a metric space  $(X, d)$ , define the *diameter* of a subset  $S \subseteq X$  by

$$\text{diam}(S) = \sup\{d(s, s') : s, s' \in S\}$$

Similarly, we can define the distance from a point to a set, and distance between sets, as follows:

$$\begin{aligned}d(A, x) &= \inf_{a \in A} d(a, x) \\d(A, B) &= \inf_{a \in A} d(B, a) \\ &= \inf\{d(a, b) : a \in A, b \in B\}\end{aligned}$$

But  $d(A, B)$  is **not** a metric.

# Convergence of Sequences

**Definition 5.** Let  $(X, d)$  be a metric space. A sequence  $\{x_n\}$  converges to  $x$  (written  $x_n \rightarrow x$  or  $\lim_{n \rightarrow \infty} x_n = x$ ) if

$$\forall \varepsilon > 0 \exists N(\varepsilon) \in \mathbf{N} \text{ s.t. } n > N(\varepsilon) \Rightarrow d(x_n, x) < \varepsilon$$

Notice that this is exactly the same as the definition of convergence of a sequence of real numbers, except we replace the standard measure of distance  $|\cdot|$  in  $\mathbf{R}$  by the general metric  $d$ .



Since  $x \neq x'$ ,  $d(x, x') > 0$ . Let

$$\varepsilon = \frac{d(x, x')}{2}$$

Then there exist  $N(\varepsilon)$  and  $N'(\varepsilon)$  such that

$$\begin{aligned} n > N(\varepsilon) &\Rightarrow d(x_n, x) < \varepsilon \\ n > N'(\varepsilon) &\Rightarrow d(x_n, x') < \varepsilon \end{aligned}$$

Choose

$$n > \max\{N(\varepsilon), N'(\varepsilon)\}$$

Then

$$\begin{aligned}d(x, x') &\leq d(x, x_n) + d(x_n, x') \\ &< \varepsilon + \varepsilon \\ &= 2\varepsilon \\ &= d(x, x') \\ d(x, x') &< d(x, x')\end{aligned}$$

a contradiction.







## Cluster Points

**Definition 6.** An element  $c$  is a cluster point of a sequence  $\{x_n\}$  in a metric space  $(X, d)$  if  $\forall \varepsilon > 0$ ,  $\{n : x_n \in B_\varepsilon(c)\}$  is an infinite set. Equivalently,

$$\forall \varepsilon > 0, N \in \mathbf{N} \exists n > N \text{ s.t. } x_n \in B_\varepsilon(c)$$

**Example:**

$$x_n = \begin{cases} 1 - \frac{1}{n} & \text{if } n \text{ even} \\ \frac{1}{n} & \text{if } n \text{ odd} \end{cases}$$

For  $n$  large and odd,  $x_n$  is close to zero; for  $n$  large and even,  $x_n$  is close to one. The sequence does not converge; the set of cluster points is  $\{0, 1\}$ .

# Subsequences

If  $\{x_n\}$  is a sequence and  $n_1 < n_2 < n_3 < \dots$  then  $\{x_{n_k}\}$  is called a *subsequence*.

Note that a subsequence is formed by taking some of the elements of the parent sequence, *in the same order*.

**Example:**  $x_n = \frac{1}{n}$ , so  $\{x_n\} = \left(1, \frac{1}{2}, \frac{1}{3}, \dots\right)$ . If  $n_k = 2k$ , then  $\{x_{n_k}\} = \left(\frac{1}{2}, \frac{1}{4}, \frac{1}{6}, \dots\right)$ .

## Cluster Points and Subsequences

**Theorem 5** (2.4 in De La Fuente, plus ...). *Let  $(X, d)$  be a metric space,  $c \in X$ , and  $\{x_n\}$  a sequence in  $X$ . Then  $c$  is a cluster point of  $\{x_n\}$  if and only if there is a subsequence  $\{x_{n_k}\}$  such that  $\lim_{k \rightarrow \infty} x_{n_k} = c$ .*

*Proof.* Suppose  $c$  is a cluster point of  $\{x_n\}$ . We inductively construct a subsequence that converges to  $c$ . For  $k = 1$ ,  $\{n : x_n \in B_1(c)\}$  is infinite, so nonempty; let

$$n_1 = \min\{n : x_n \in B_1(c)\}$$

Now, suppose we have chosen  $n_1 < n_2 < \cdots < n_k$  such that

$$x_{n_j} \in B_{\frac{1}{j}}(c) \text{ for } j = 1, \dots, k$$

$\{n : x_n \in B_{\frac{1}{k+1}}(c)\}$  is infinite, so it contains at least one element bigger than  $n_k$ , so let

$$n_{k+1} = \min \left\{ n : n > n_k, x_n \in B_{\frac{1}{k+1}}(c) \right\}$$

Thus, we have chosen  $n_1 < n_2 < \dots < n_k < n_{k+1}$  such that

$$x_{n_j} \in B_{\frac{1}{j}}(c) \text{ for } j = 1, \dots, k, k+1$$

Thus, by induction, we obtain a subsequence  $\{x_{n_k}\}$  such that

$$x_{n_k} \in B_{\frac{1}{k}}(c)$$

Given any  $\varepsilon > 0$ , by the Archimedean property, there exists  $N(\varepsilon) > 1/\varepsilon$ .

$$\begin{aligned} k > N(\varepsilon) &\Rightarrow x_{n_k} \in B_{\frac{1}{k}}(c) \\ &\Rightarrow x_{n_k} \in B_{\varepsilon}(c) \end{aligned}$$

so

$$x_{n_k} \rightarrow c \text{ as } k \rightarrow \infty$$

Conversely, suppose that there is a subsequence  $\{x_{n_k}\}$  converging to  $c$ . Given any  $\varepsilon > 0$ , there exists  $K \in \mathbb{N}$  such that

$$k > K \Rightarrow d(x_{n_k}, c) < \varepsilon \Rightarrow x_{n_k} \in B_\varepsilon(c)$$

Therefore,

$$\{n : x_n \in B_\varepsilon(c)\} \supseteq \{n_{K+1}, n_{K+2}, n_{K+3}, \dots\}$$

Since  $n_{K+1} < n_{K+2} < n_{K+3} < \dots$ , this set is infinite, so  $c$  is a cluster point of  $\{x_n\}$ . □

## Sequences in $\mathbf{R}$ and $\mathbf{R}^m$

**Definition 7.** A sequence of real numbers  $\{x_n\}$  is increasing (decreasing) if  $x_{n+1} \geq x_n$  ( $x_{n+1} \leq x_n$ ) for all  $n$ .

**Definition 8.** If  $\{x_n\}$  is a sequence of real numbers,  $\{x_n\}$  tends to infinity (written  $x_n \rightarrow \infty$  or  $\lim x_n = \infty$ ) if

$$\forall K \in \mathbf{R} \exists N(K) \text{ s.t. } n > N(K) \Rightarrow x_n > K$$

Similarly define  $x_n \rightarrow -\infty$  or  $\lim x_n = -\infty$ .

# Increasing and Decreasing Sequences

**Theorem 6** (Theorem 3.1'). *Let  $\{x_n\}$  be an increasing (decreasing) sequence of real numbers. Then*

$$\lim_{n \rightarrow \infty} x_n = \sup\{x_n : n \in \mathbf{N}\}$$

$$\left( \lim_{n \rightarrow \infty} x_n = \inf\{x_n : n \in \mathbf{N}\} \right)$$

*In particular, the limit exists.*



## Lim Sups and Lim Infs

Consider a sequence  $\{x_n\}$  of real numbers. Let

$$\begin{aligned}\alpha_n &= \sup\{x_k : k \geq n\} \\ &= \sup\{x_n, x_{n+1}, x_{n+2}, \dots\} \\ \beta_n &= \inf\{x_k : k \geq n\} \\ &= \inf\{x_n, x_{n+1}, x_{n+2}, \dots\}\end{aligned}$$

Either  $\alpha_n = +\infty$  for all  $n$ , or  $\alpha_n \in \mathbf{R}$  and  $\alpha_1 \geq \alpha_2 \geq \alpha_3 \geq \dots$ .

Either  $\beta_n = -\infty$  for all  $n$ , or  $\beta_n \in \mathbf{R}$  and  $\beta_1 \leq \beta_2 \leq \beta_3 \leq \dots$ .

## Lim Sups and Lim Infs

**Definition 9.**

$$\begin{aligned}\limsup_{n \rightarrow \infty} x_n &= \begin{cases} +\infty & \text{if } \alpha_n = +\infty \text{ for all } n \\ \lim \alpha_n & \text{otherwise.} \end{cases} \\ \liminf_{n \rightarrow \infty} x_n &= \begin{cases} -\infty & \text{if } \beta_n = -\infty \text{ for all } n \\ \lim \beta_n & \text{otherwise.} \end{cases}\end{aligned}$$

**Theorem 7.** *Let  $\{x_n\}$  be a sequence of real numbers. Then*

$$\begin{aligned}\lim_{n \rightarrow \infty} x_n &= \gamma \in \mathbf{R} \cup \{-\infty, \infty\} \\ \Leftrightarrow \limsup_{n \rightarrow \infty} x_n &= \liminf_{n \rightarrow \infty} x_n = \gamma\end{aligned}$$

# Increasing and Decreasing Subsequences

**Theorem 8** (Theorem 3.2, Rising Sun Lemma). *Every sequence of real numbers contains an increasing subsequence or a decreasing subsequence or both.*

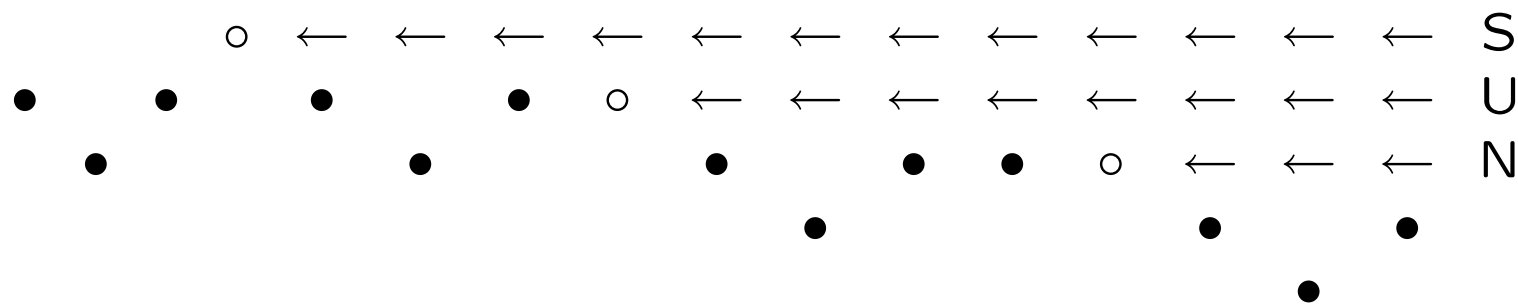

*Proof.* Let

$$S = \{s \in \mathbf{N} : x_s > x_n \quad \forall n > s\}$$

Either  $S$  is infinite, or  $S$  is finite.

If  $S$  is infinite, let

$$\begin{aligned}n_1 &= \min S \\n_2 &= \min (S \setminus \{n_1\}) \\n_3 &= \min (S \setminus \{n_1, n_2\}) \\&\vdots \\n_{k+1} &= \min (S \setminus \{n_1, n_2, \dots, n_k\})\end{aligned}$$

Then  $n_1 < n_2 < n_3 < \dots$ .

$$\begin{array}{ll} x_{n_1} > x_{n_2} & \text{since } n_1 \in S \text{ and } n_2 > n_1 \\ x_{n_2} > x_{n_3} & \text{since } n_2 \in S \text{ and } n_3 > n_2 \\ & \vdots \\ x_{n_k} > x_{n_{k+1}} & \text{since } n_k \in S \text{ and } n_{k+1} > n_k \\ & \vdots \end{array}$$

so  $\{x_{n_k}\}$  is a strictly decreasing subsequence of  $\{x_n\}$ .

If  $S$  is finite and nonempty, let  $n_1 = (\max S) + 1$ ; if  $S = \emptyset$ , let  $n_1 = 1$ . Then

$$\begin{array}{ll} n_1 \notin S & \text{so } \exists n_2 > n_1 \text{ s.t. } x_{n_2} \geq x_{n_1} \\ n_2 \notin S & \text{so } \exists n_3 > n_2 \text{ s.t. } x_{n_3} \geq x_{n_2} \\ & \vdots \\ n_k \notin S & \text{so } \exists n_{k+1} > n_k \text{ s.t. } x_{n_{k+1}} \geq x_{n_k} \\ & \vdots \end{array}$$

so  $\{x_{n_k}\}$  is a (weakly) increasing subsequence of  $\{x_n\}$ .



## Bolzano-Weierstrass Theorem

**Theorem 9** (Thm. 3.3, Bolzano-Weierstrass). *Every bounded sequence of real numbers contains a convergent subsequence.*

*Proof.* Let  $\{x_n\}$  be a bounded sequence of real numbers. By the Rising Sun Lemma, find an increasing or decreasing subsequence  $\{x_{n_k}\}$ . If  $\{x_{n_k}\}$  is increasing, then by Theorem 3.1',

$$\lim x_{n_k} = \sup\{x_{n_k} : k \in \mathbf{N}\} \leq \sup\{x_n : n \in \mathbf{N}\} < \infty$$

since the sequence is bounded; since the limit is finite, the subsequence converges. Similarly, if the subsequence is decreasing, it converges. □